

Surface Grinder

EASY NC Series

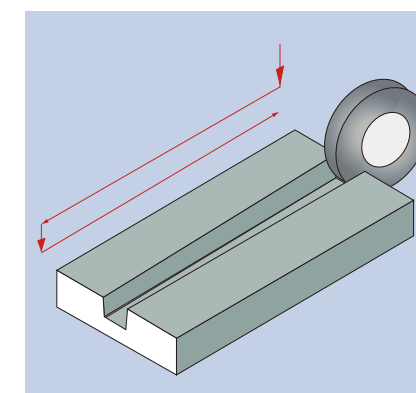
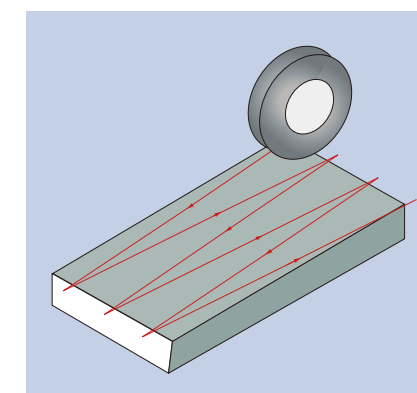
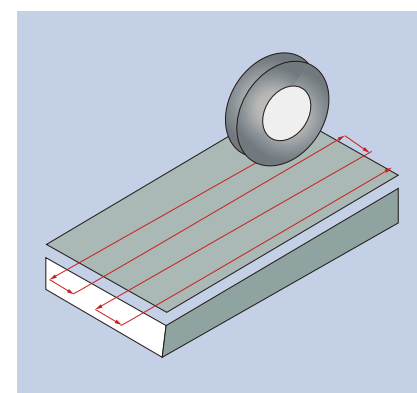

Grinder Professionals

e-tech USA

6435 Alondra Blvd,
Paramount, CA.90723
TEL: +1(562)220-1675
Mail: info@supertecusa.com

e-tech Asian Operations Center

No.36, Ln.686, Sec. 4, Chanping Rd.,
Daya Dist., Taichung City 428
Taiwan (R.O.C)
TEL: +886-4-2568-6418
Mail: info@etechtw.com

1 EASY Series Surface Grinder NC Type

Features

Simple operation and high precision surface grinder, the best solution for you!

Specilly built for mold and high-tech electronics industries :

- E-tech Easy series surface grinder present unique grinding accuracy and surface finish, and we offer both saddle and type option for different tasks. The structure design provides high precision and high rigidity results, especially for large parts and creates praising accuracy.
- EASY series supply PLC control panel and color touch screen with strong function and easy operation; furthermore, auto grinding function met the target of time saving and high efficiency.



Saddle type structure
Model : EASY-1224 \ EASY-1632



Column type structure
Model: EASY-2040 \ EASY-2448

NC Controller

Easy series surface grinder provide PLC control in combination of color touch screen and uer-friendly operation design. Operator can simply set up the grinding amount and be ready to start a grinding cycle. The control system will save the last grinding parameter setting automatically, and operator only have to press "cycle start" button to repeat the previous set parameter and start the cycle again.



Setting Display

Main Menu

Mode Selection

CrissCross Step-Cross Plunge

Feed Selection

FRONT REAR LEFT RIGHT

Park Selection

LEFT RIGHT NEXT

Setting Screen

location:

Total Stock Removal : _____ mm

Fine-feed Amount : _____ mm

Coarse Increment : _____ mm

Fine Increment : _____ mm

Sparkout Passes : _____

Clearance : _____

Time : _____ sec

Data input keyboard

7 8 9 CLR

4 . 6 ▲

1 2 3 ▼

0 - ENT

Crossfeed distance and be pre-set, and operator can also choose to set to set the front or rear position to feed from dual sides or one side of the working table. Grinding wheel infeed movement can also be set to start grinding from dual sides or either one side of the working table. The working table longitudinal movement distance can also be set precisely and steady, and operator can also choose to set the start / stop position on the left or right side of the table. (Auto. Dressing attachment can be offered as optional accessory)

Grinding Cycle

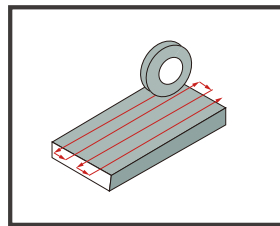

1. Step grinding

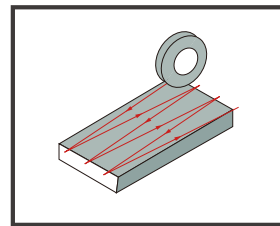

2. Criss-cross grinding

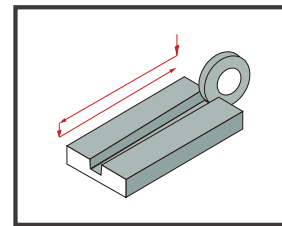

3. Plunge grinding

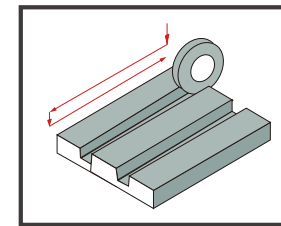

4. Multi-slicing grinding (opt.)

3 Column Type Surface Grinder Design Feature

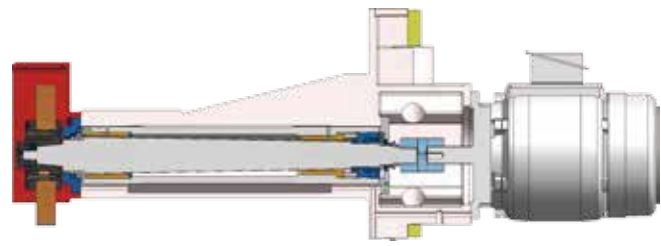

- Hydrodynamic spindle offers steady oil pressure supply to support the spindle. Spindle run-out is less than 0.002mm, and stiffness over 50Kgf/um. This feature is suitable for both light and heavy duty grinding operation. The hydraulic circuit is connected to a pressure sensor, once the oil pressure is too low, the grinding wheel will automatically stopped to prevent causing damage to the spindle.
- Bearing type spindle features high accuracy, non-vibration, low thermal growth. The spindle is equipped with precision angular contact ball bearings and the grease sealed lubrication makes the spindle easy to maintain and ensure of continuous operation. The spindle run-out is less than 0.002mm.
- X / Z Axis guideway lubrication system is equipped with pressure sensing function and make sure enough lubrication pressure is supplied.

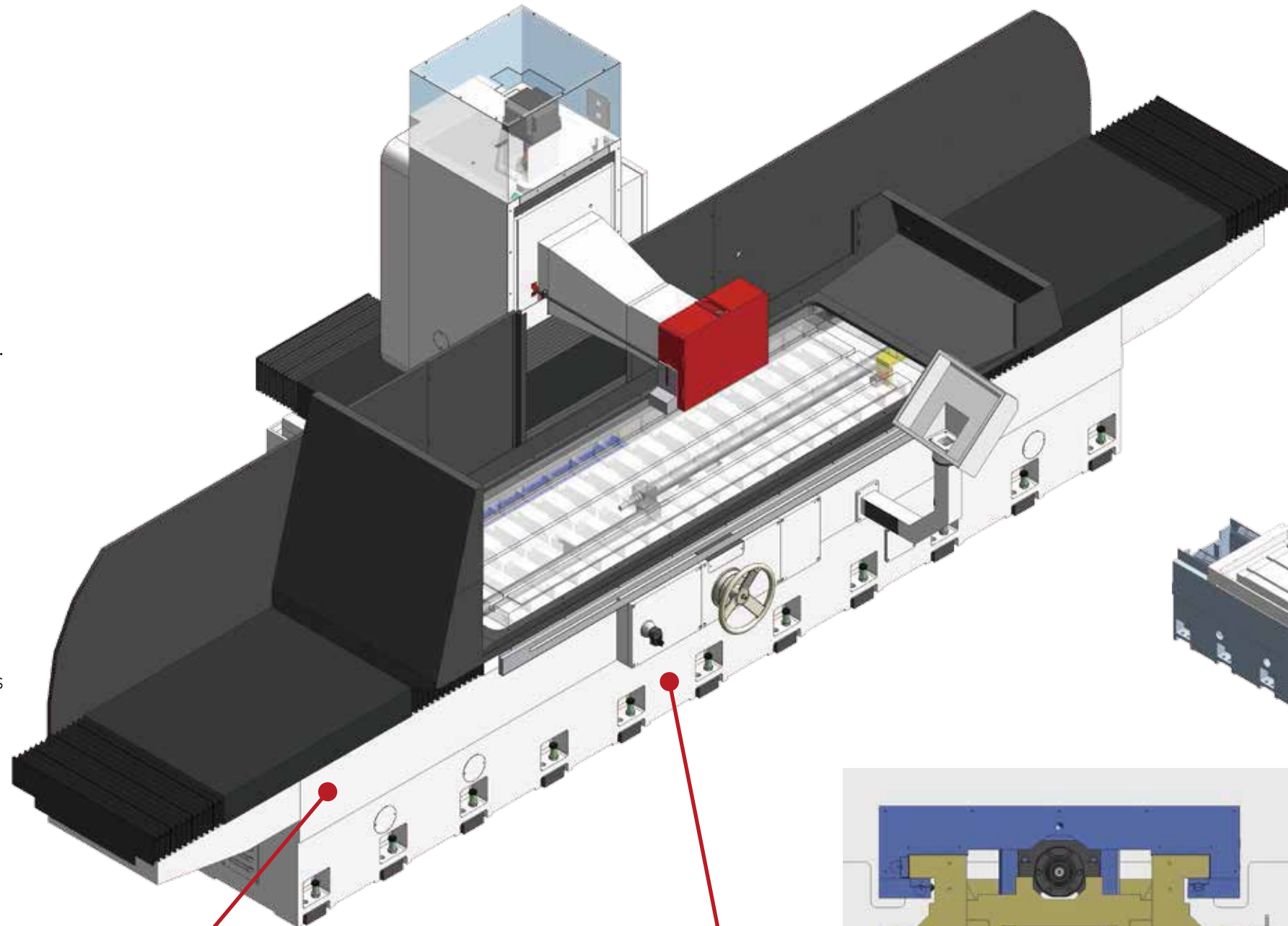

E-tech offers wider and heavier design of the column, which offers high stability and rigidity. The lubrication is supplied independently to extend the lifetime.

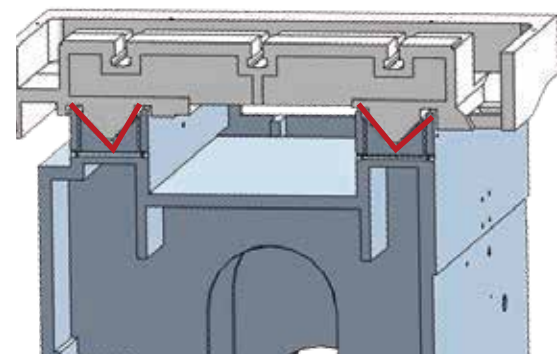
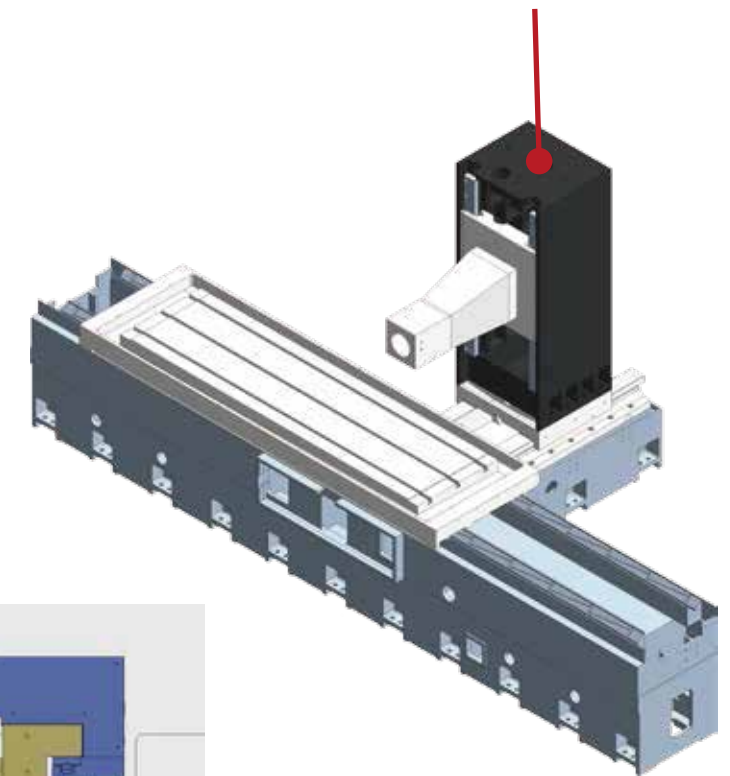

X Axis

X Axis Working table guideway double V design

For large parts and heavy duty jobs, the working-table slideways are modified as double V guideways. Deepen and widen the guideways with large span design offers the working table steady and smooth movement.

X Axis guideway is precisely hand scraped, oil film lubrication supplied, and Turcite-B coated to ensure positioning accuracy and long term usage.

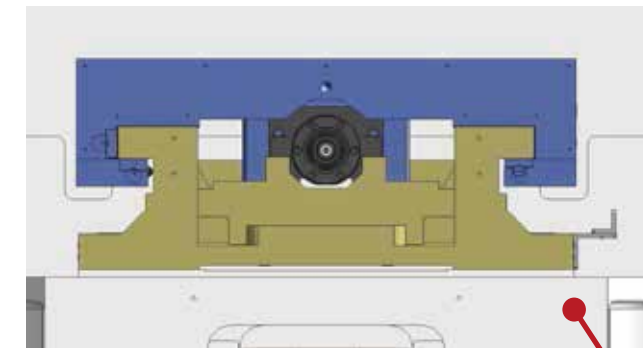

The integral "T" shape base is manufactured from Meehanite casting, with tempering & stress-relief treatment to ensure structure stability and avoid transformation.

The base is 2.5 times longer than the working table, which makes the working table fully supported during the whole travel, and this function also increase the supporting rigidity during grinding operation.

Z Axis Saddle Structure

The saddle is precisely scraped and driven by precise ballscrew to move along the box guideway, increasing machine rigidity and extend the machine lifetime.

5 Specification : EASY NC Series

Model	Unit	EASY-1224NC	EASY-1632NC	EASY-2040NC	EASY-2060NC	Model	Unit	EASY-2448NC	EASY-2460NC	EASY-2480NC	EASY-24100NC				
General Capacity	Max. grinding length	mm	600	800	1050	1550	General Capacity	Max. grinding length	mm	1250	1550	2050	2550		
	Max. grinding width	mm	300	400	500	500		Max. grinding width	mm	625	625	625	625		
	Distance (from table surface to spindle centerline)	mm	550	550	600	600		Distance (from table surface to spindle centerline)	mm	700	700	700	700		
	Max. load on table (incl. magnetic chuck)	kg	400	580	850	850		Max. load on table (incl. magnetic chuck)	kg	850	850	850	850		
Working table	Table size	mm	300x600	400x800	500x1000	500x1500	Working table	Table size	mm	600x1200	600x1500	600x2000	600x2500		
	T slot dimension x quantity		14x1	14x3	14x3	14x3		T slot dimension x quantity		20x3	20x3	20x3	20x3		
	Distance from table surface to floor	mm	950	950	920	920		Distance from table surface to floor	mm	930	930	930	930		
	Standard magnetic chuck size	mm	300x600	400x800	500x1000	500x1500		Standard magnetic chuck size	mm	600x1200	600x1500	600x2000	600x2500		
	Saddle / Column moving	-	Saddle	Saddle	Column	Column		Saddle / Column moving	-	Column	Column	Column	Column		
Longitudinal Movement	Travel distance	mm	650	850	1100	1600	Longitudinal Movement	Travel distance	mm	1350	1650	2150	2650		
	- X Axis	Table speed	m/min	3~25	3~25	3~25		3~25	- X Axis	Table speed	m/min	3~25	3~25	3~25	3~25
	Manual travel	mm	700	900	X	X		Manual travel	mm	X	X	X	X		
Auto. Cross Movement	Automatic increment feeds	mm	360	460	550	550	Auto. Cross Movement	Automatic increment feeds	mm	725	725	725	725		
	- Z Axis	Rapid travel (60Hz/50Hz)	mm/min	1710/1425	1710/1425	1710/1425		1710/1425	- Z Axis	Rapid travel (60Hz/50Hz)	mm/min	1710/1425	1710/1425	1710/1425	1710/1425
	Min. input unit (NCII model, opt.)	mm	0.001	0.001	0.001	0.001		Min. input unit (NCII model, opt.)	mm	0.001	0.001	0.001	0.001		
Manual Cross Movement	Crossfeed Z axis motor	Kw	0.18	0.18	0.375	0.375	Manual Cross Movement	Crossfeed Z axis motor	Kw	0.375	0.375	0.375	0.375		
	Manual travel	mm	370	470	575	575		Manual travel	mm	725	725	725	725		
	- Z Axis	Handwheel per graduation	mm	0.02	0.02	0.02		0.02	- Z Axis	Handwheel per graduation	mm	0.02	0.02	0.02	0.02
Vertical Downfeed	Handwheel per revolution	mm	5	5	5	5	Vertical Downfeed	Handwheel per revolution	mm	5	5	5	5		
	Automatic downfeed travel	mm	400	400	500	500		Automatic downfeed travel	mm	500	500	500	500		
	- Y Axis	Max. infeed speed	m/min	2.5	2.5	2.5		2.5	- Y Axis	Max. infeed speed	m/min	2.5	2.5	2.5	2.5
Grinding Wheel	Min. input unit	mm	0.001	0.001	0.001	0.001	Grinding Wheel	Min. input unit	mm	0.001	0.001	0.001	0.001		
	Y axis servo motor	Kw	1	1	1	1		Y axis servo motor	Kw	3	3	3	3		
	Wheel size (OD x W x ID)	mm	Ø355x50xØ127	Ø355x50xØ127	Ø405x50xØ127	Ø405x50xØ127		Wheel size (OD x W x ID)	mm	Ø405x50xØ127	Ø405x50xØ127	Ø405x50xØ127	Ø405x50xØ127		
Motor	Spindle speed (60Hz/50Hz)	rpm	1800/1500	1800/1500	1800/1500	1800/1500	Motor	Spindle speed (60Hz/50Hz)	rpm	1800/1500	1800/1500	1800/1500	1800/1500		
	Spindle motor	kw	3.75/5.6(opt.)	3.75/5.6(opt.)	5.625/7.5(opt.)	5.625/7.5(opt.)		Spindle motor	kw	11	11	11	11		
	Max. torque	Nm	26/36	26/36	36/49	36/49		Max. torque	Nm	71	71	71	71		
	Hydraulic motor	kw	1.5	1.5	2.25	2.25		Hydraulic motor	kw	3.75	3.75	5.5	5.5		
Packing dimension	Lubrication motor	kw	0.075	0.075	0.025	0.025	Packing dimension	Lubrication motor	kw	0.187	0.187	0.187	0.187		
	(LxWxH)	cm	285x225x249	320x226x255	360x228x255	542x228x255		(LxWxH)	cm	424x2300x255	542x228x255	600x228x300	700x228x300		
	Net weight	kg	3000	3500	5900	7100		Net weight	kg	6600	8800	10420	10900		
Gross weight	kg	3500	4500	6900	8600	Gross weight	kg	7600	9800	10920	11700				

*All machine design and specification are subject to change without prior notice.

Standard Accessories

Grinding Wheel+wheel flange
 PLC + Touch Screen + Control Panel
 Y-axis Ball Screw + Servo Motor
 Hydraulic System w/cooling fan
 Operating Manual & Part Lists
 Leveling Bolts w/ Blocks

Balancing Stand w/Arbor
 Standard Coolant Tank
 Semi-enclosure Splash Guard
 Grinding Wheel Extractor
 Diamond Dresser & Stand
 Tools & Tool Box

Optional Accessories

(Fine Pole) Electromagnetic Chuck w/Auto. Demagnetizer
 Electromagnetic Chuck w/Auto. Demagnetizer
 Coolant system with magnetic separator & paper filter
 Coolant system with magnetic separator
 Coolant system with paper filter
 Y & Z Axis (Vertical & Cross) linear scale w/ DRO
 Y Axis (Vertical) linear scale w/ DRO
 Overhead Parallel Dressing Attachment (Manual/Hydraulic)
 "Overhead Parallel Dressing Attachment w/ Automatic Compensation (Stepping motor)"

Permanent Magnetic Rotary Chuck
 Dual side dressing attachment
 Spare grinding wheel flange
 Angle dressing attachment
 Radius dressing attachment
 Oil & mist collecting system
 Grinding wheel inverter
 Dust collector