

CNC Vertical Grinder EGV Series

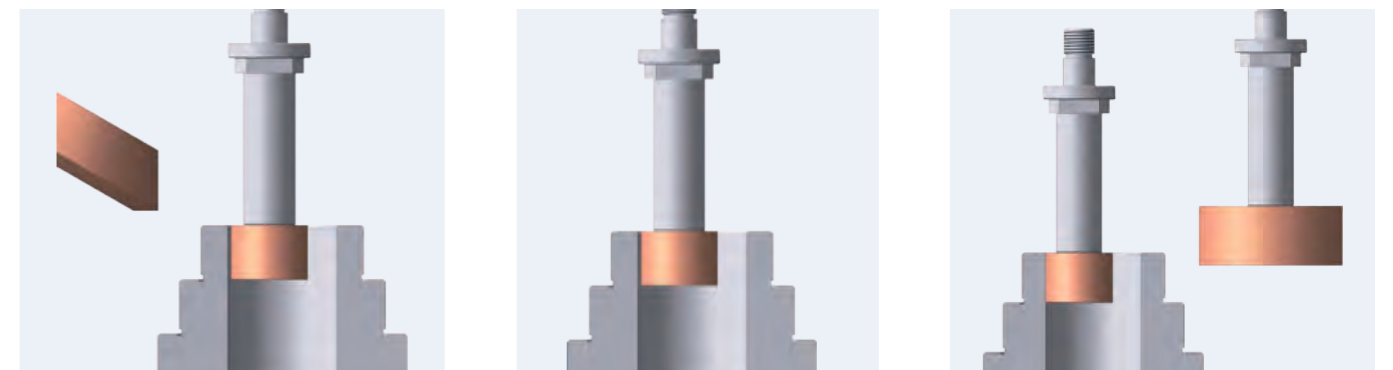

Grinder Professionals

e-tech USA

6435 Alondra Blvd, Paramount,
CA.90723

E-mail : info@supertecusa.com

TEL : (562) 220-1675

e-tech Asian Operation Center

No.36, Ln.686, Sec.4, Changping Rd.,
Daya Dist., Taichung City 428

Taiwan(R.O.C)

E-mail : info@etechtw.com

TEL : 886-425686418

WEB: www.etechtw.com



E-tech Machinery Grinder Professional

**Machine Features and
Wheel Dressing Cycle**

1

Structure Features

3

**iGrind Graphic
Conversational Screen**

5

Specification

7



FACEBOOK



INSTAGRAM



YOUTUBE



WEBSITE

1 EGV SERIES CNC VERTICAL GRINDER

e-tech is specialized in cylindrical component grinding. At many customers' request from different industries, EGV-600/800CNC is finally designed and announced.

Features

- The structural engineering of e-tech has always been known for having high demands toward machine rigidity and structural strength. In order to exceed the limitations of grinding the long-deep hole in vertical grinders, e-tech designed the structure body with the large fixed column with slides, so the machine can grind the depth to 550mm. As for the transmission unit, we use the highest level of accuracy including 6 rows ball bearing linear guides and C1 level ball screw from Japan NSK.
- To present the perfect MIT skills, E-tech put the price competition in the market aside and insist on pursuing the best quality by not putting the sales at first. The whole machine structure not only completely passes an official third party PMC' s verification (Precision Machinery Research Development Center,), but also every accessories are chosen with the best choices which we recommend for our customers as well.



EGV-600CNC

CNC Controller

- iGrind conversational program: Simple, flexible and easy to operate, allowing the operators to put their hands on the machine within the shortest amount of time.
- Graphic conversational interface makes operation without borders between words and languages.
- Comprehensive grinding paths for various industries
- Includes 18 grinding steps that fulfill different shapes of components
- Includes a support guide, making the value input process easier among various grinding parameters setting.
- The free shaping function can flexibly modify the shape of the grinding wheel according to customers' requests.
- MPG simulation function to test-run for the program to avoid accidental wheel crash



Standard grinding cycles and multi-steps graphic conversational functions

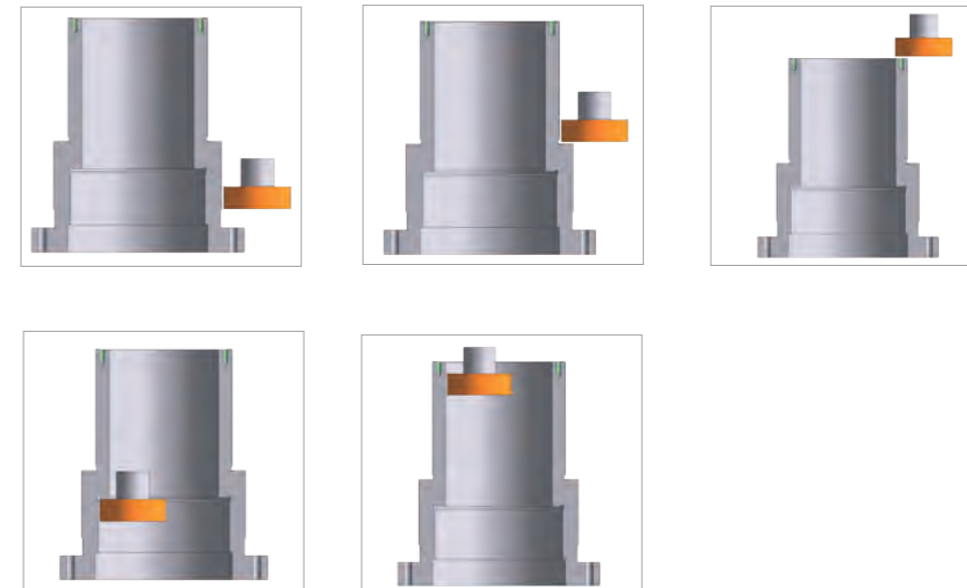

Grinding wheel dressing graphic illustration

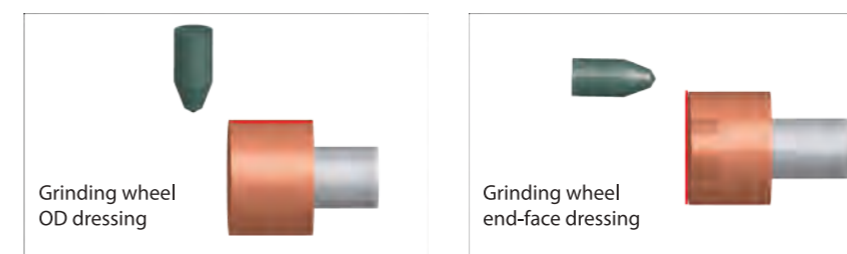

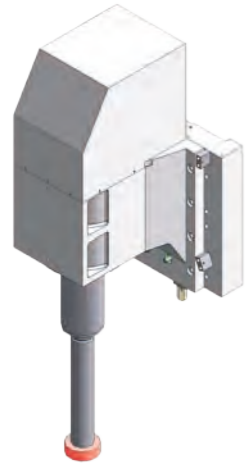

Grinding Spindle

e-tech chooses to use built-in type spindle, not only it has the feature of high cutting speed, but also has the advantage of good grinding capacity, low vibration, high accuracy, and flexible space arrangement. Long spindle nose design is easier to allow the spindle to enter deep bores for grinding. In this way, it reduces the length of the grinding wheel arbor, and increases the rigidity during the grinding operation at the same time.



Measurement Device (Opt.)

For bigger workpiece operation, usually the operators will feel uncertainty toward the position and accuracy inspection. In this case, e-tech had specially planned out using LP2 probe with B53 mechanism which is specialized for measurement during grinding operation. Plus the gauge block, it not only highly shortens the time for tool positioning, but also achieves the best accuracy by performing another measurement after the grinding cycle finishes.

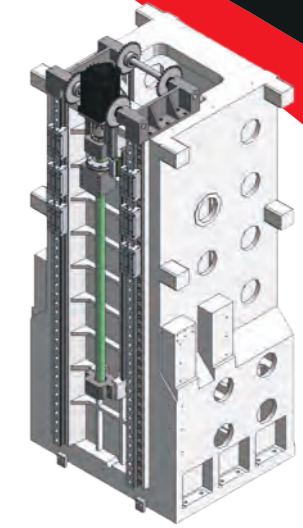
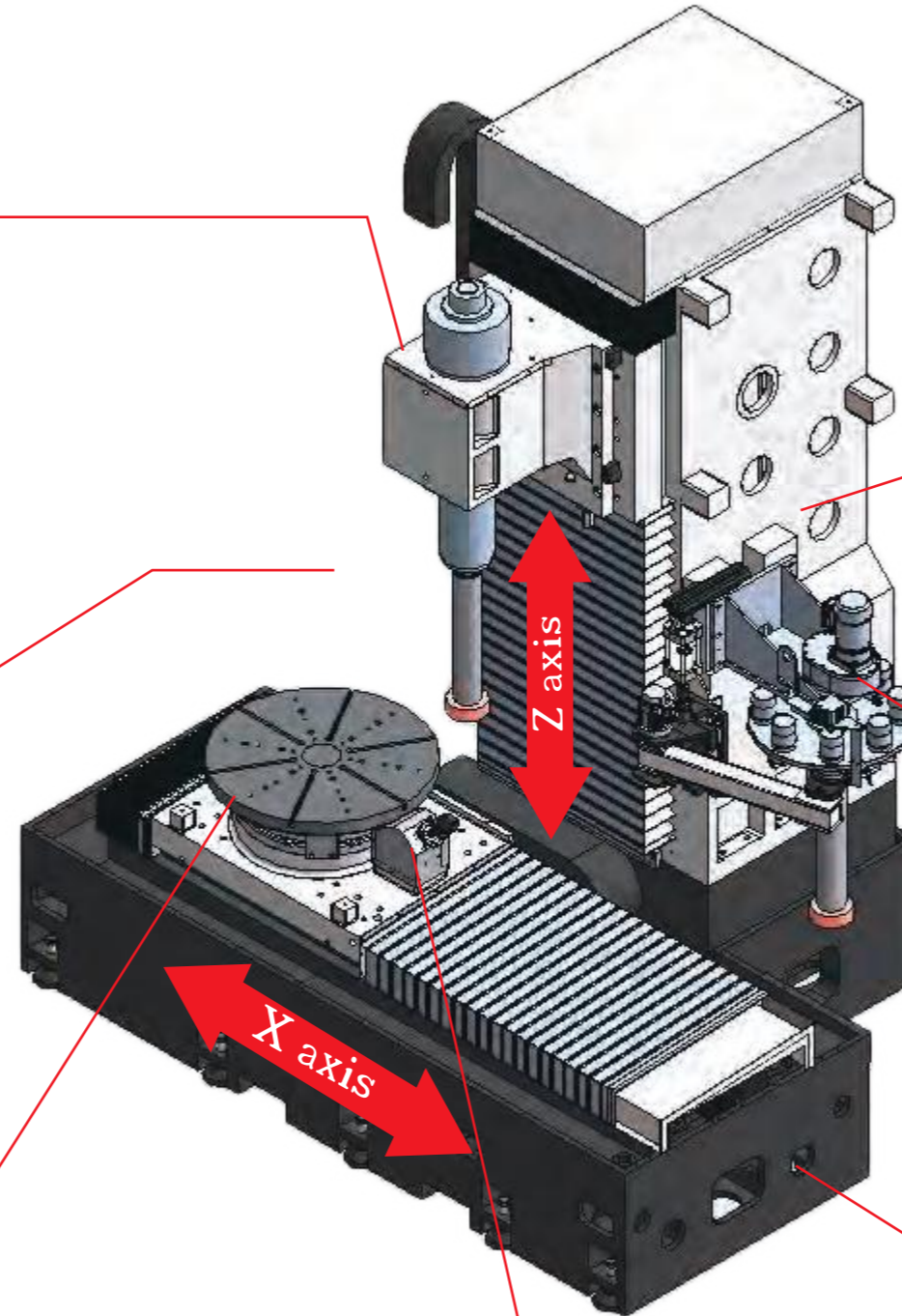

High Precision Linear Scale

- All axes using NSK C1 grade high precision ball screw with the features including high precision, high rigidity, high lead, and predictable service life.
- The leading manufacturer using 6 rows ball bearing linear guides, using longer sliding block to achieve features of average weight and accuracy, and low friction.

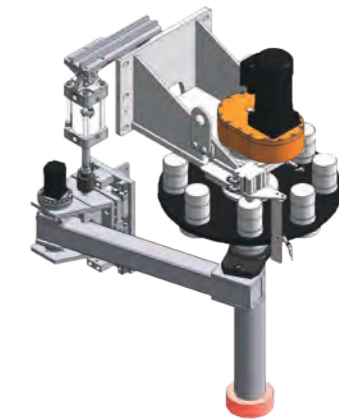

ATC Tool Changing System

The carousel tool magazine with ATC tool change system, not only provides the high stability, but also increases the efficiency for tool changing. The tool magazine could reserve around 6 to 8 tool holders in stock. In this case, it could still perform the best surface roughness even facing workpiece with complicated operation requirement.

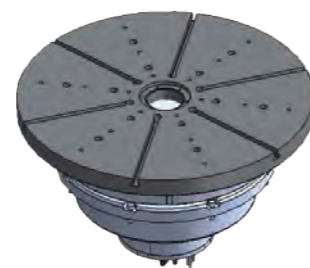

Hydrostatic Rotary Table

As for the rotary table, e-tech uses the hydrostatic design with the feature of zero steel contact. Not only it could provide high rotating accuracy with 0.001mm, but also it has a long servicing life-time. The high rigidity design provides itself a high loading capacity. In static loading condition, the weight load capacity reaches to 1200kg.

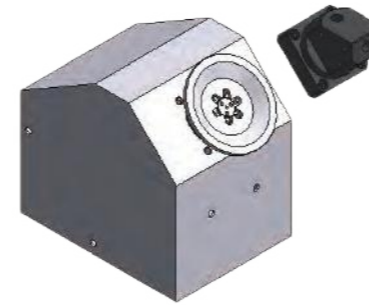

Diamond Roller Dresser (Opt.)

Comparing with the ordinary diamond dressers, diamond roller has the feature of not easily worn-off, high shaping accuracy, and high dressing efficiency. According to customer, It's also can replace diamond roller with diamond dressers.

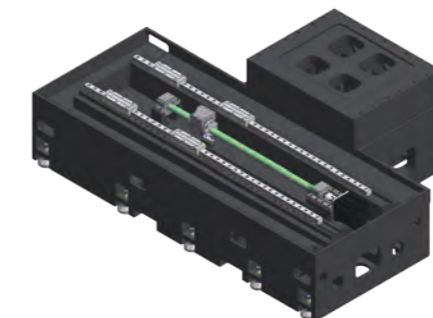

Base

Low gravity machine structure and high rigidity machine base design can successfully control the stability of the heat source. Also, the single-side water flow design can reduce the effect caused by temperature, and remove chips or debris to keep the machine clean.

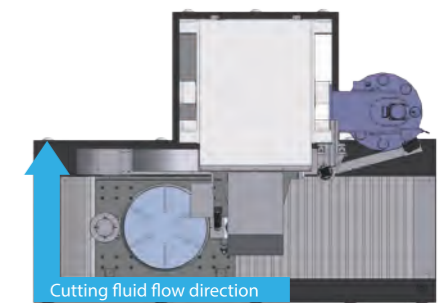

- Operation set-up through simple graphic display icons for easy learning progress

Edit/Execute File Management GW Option

Machine Positioning & Situation Display

Sequence Setting: Select GW options & grinding modes

Former Page

Grinder Mode Selection

Intelligence Sequence Selection

Axial Compensation Selection

- Grinding mode selection

ID-Straight feed	ID-End-face	ID-Taper	ID-Reverse Grooving
OD-Straight feed	OD-End-face	OD-Taper	OD-Reverse Grooving

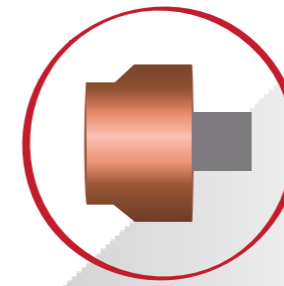

Type	X	Z	R/C
1	P(ABS)	20.0000	0.0000
2	P(ABS)	20.0000	10.0000
3	P(ABS)	10.0000	10.0000
4	P(ABS)	10.0000	16.0000
5	A(COM)(INC)	-4.0000	4.0000
6	P(INC)	0.0000	12.0000
7			
8			
9			
10			

P(ABS) P(INC) A(COM) A(COM) R/C INSERT DEL CLEAR SAVE

Grinding Wheel Dressing

With the iGrind high speed box type dressing function, the operator just have to input the necessary parameters for the dresser and the geometric data of the profile to create the optimal dressing path. Thus, it drastically reduces the wheel dressing time.

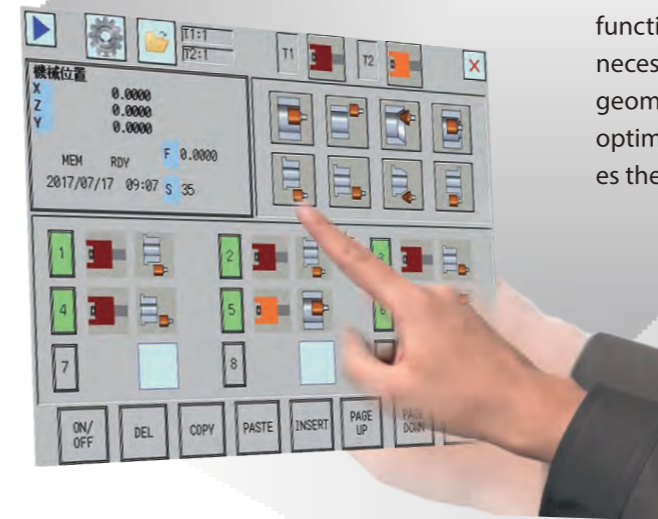

機械位置 X: 16.9165 Z: 17.2119
 MEM RDY F 0.0000
 2017/05/10 14:15 S 35

0.10 0.01
 100.00 500.00
 2.00

Sequence setting: Select grinding wheel options and grinding modes

機械位置 X: 0.0000 Z: 0.0000
 MEM RDY F 0.0000
 2017/05/10 15:40 S 35

38.8000
 26.5000

0.10 0.01
 100.00 500.00
 2.00

Convenient and quick wheel dressing point setting

Model		EGV-600 CNC	EGV-800 CNC
Grinding Capacity	Max. ID ϕ	mm $\phi 70 \sim \phi 550$	mm $\phi 70 \sim \phi 750$
	Max. OD ϕ	mm $\phi 600$	mm $\phi 800$
	ID Length	mm 550	mm 550
	OD Length	mm 550	mm 550
	Max. Swing ϕ	mm $\phi 600$	mm $\phi 800$
	Max. Workpiece weight	kg 800	kg 800
Grinding Wheel	Spindle Speed	rpm 10000	rpm 10000
	Tool Holder	- HSK-A100	- HSK-A100
X Axis	Spindle Turning Angle	- Fixed type	- Fixed type
	Max. Feeding Stroke	mm 1000	mm 1000
	Max. Feeding Speed	m/min 15	m/min 15
	Min. Feeding Unit	mm 0.0001	mm 0.0001
Z Axis	Max. Feeding Stroke	mm 1200	mm 1200
	Max. Feeding Speed	m/min 15	m/min 15
	Min. Feeding Unit	mm 0.0001	mm 0.0001
Work Table	Table Size	mm $\phi 600$	mm $\phi 800$
	Max. Swiveling Speed	rpm 200R.P.M (Hydrostatic pressure)	rpm 200R.P.M (Hydrostatic pressure)
Auto Tools Changer	Max. Grinding Wheel	mm $\phi 250$	mm $\phi 250$
	Max. Grinding Wheel Weight	kg 8	kg 8
	Grinding Wheel Capacity	- 8	- 8
		(According to grinding wheel)	(According to grinding wheel)
Motor	GW Spindle Motor	Kw 25	Kw 25
	Work Table Motor (DD Direct Drive)	Kw 3.1	Kw 3.1
	Hydraulic Motor	Hp 4	Hp 4
	Coolant	Hp 2.5	Hp 2.5
	X Axis Servo Motor	Kw 4.5	Kw 4.5
	Z Axis Servo Motor	Kw 4.5	Kw 4.5
Machine	Net Weight	kg 22000	kg 22500
	Gross Weight	kg 23000	kg 23500
	Packing Dimension(LxWxH)	mm 3000 x 2700 x 3700	mm 3000 x 2700 x 3700

Measurement

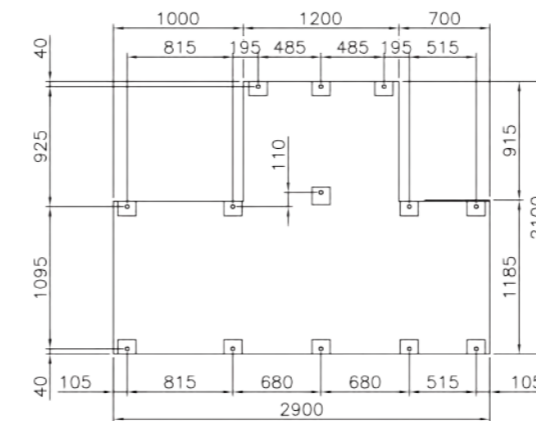
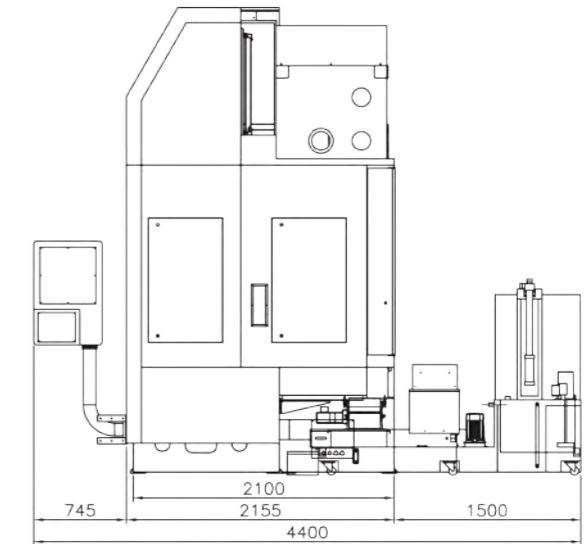
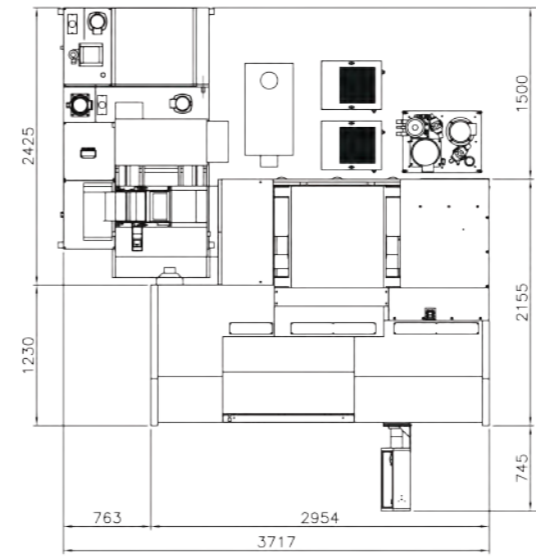

Standard Accessories

- | | |
|--|--|
| Mitsubishi CNC Controller M80 | HSK Grinding wheel spindle (2pcs) |
| Grinding wheel spindle (HSK-A100) | ATC Tool changer with Disk type magazine |
| NSK Ballscrew & linear guide way (made in Japan) | Rotary table with direct drive motor |
| Auto. lubrication system | X axis with Closed-loop Mitsubishi Precision linear scale(Mitsubishi 0.05um) |
| Levelling bolts and blocks | Electricity Carbinet w/ Heat Exchanger |
| Tools and tool box | Rotary table with T-slot |
| Full-enclosed splash guard | LED working light |
| Diamond Dresser (3 point) | Operation manual and part lists |
| 3-color signal light | Electricity Diagrams |

Optional Accessories

- | | |
|--|---|
| Mitsubishi controller (M80) iGrind program | Power sensor dressing crash control system (current indicator) |
| Permanent Magnetic Rotary Chuck 600mm (Include 8 customized magnets) | Renishaw LP2 tool setting and measuring device (with gauge block) |
| Coolant system with magnetic separator 120L/min | Grinding wheel spindle for deep hole grinding |
| Coolant system with paper filter 120L/min | Z axis with Closed-loop Mitsubishi Precision linear scale (Mitsubishi 0.05um) |
| Oil Skimmer (Oil & Water separator) | Customized chuck (fixture) |
| Coolant system chiller | |
| HSK-A100 Grinding wheel spindle | |
| Oil & mist collecting system(LOSMA) | |
| Diamond roller dressing device | |
| Filstar JAPAN high capability filtering system | |

* e-tech reserves the right to change specifications without notice